

CHUCKS

Quick clamping chucks

D-D

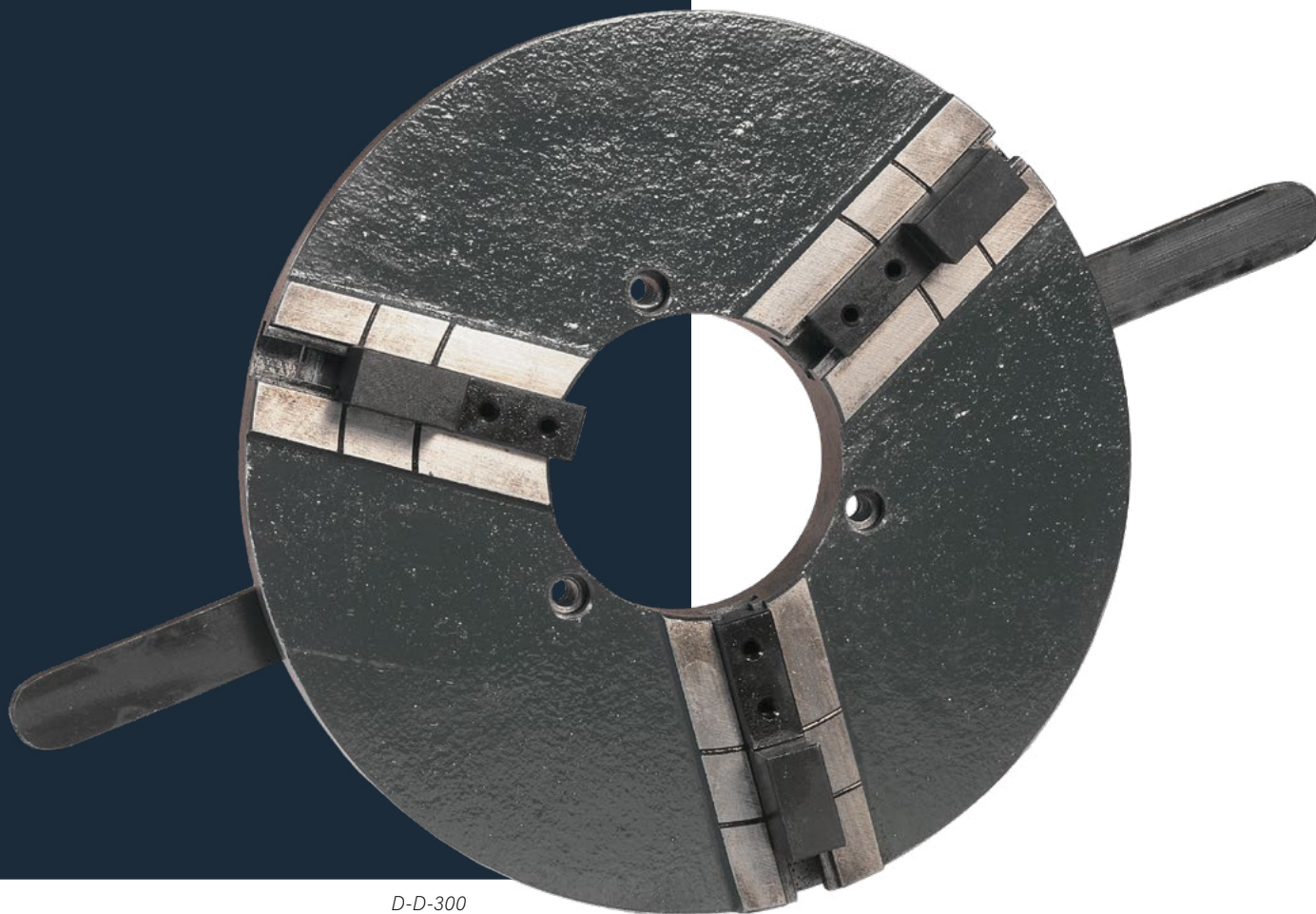

D-D-300

UMETA
fast. safe. easy.



CHUCKS

Quick clamping chucks

D-D

The D-D Series chucks are used for clamping work pieces for welding, and are mountable on any brand of positioner. The D-D series feature a quick clamp open/close lever to firmly lock and release the workpiece. A wrench is not needed, because the levers in the 3-jaw chuck are integrated.

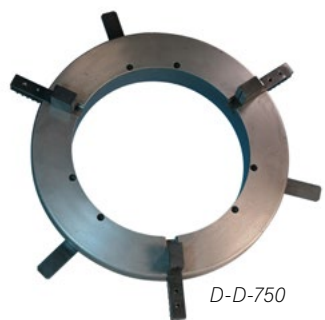

D-D-750



D-D-200

D-D-500



D-TLP-06

FEATURES

- 3 or 4 self-centring jaws
- Reversible jaws
- Rapid tightening handles allow fast loading and unloading
- Suitable for smaller welding positioners given lightweight and low-profile design



CHUCKS

Quick clamping chucks

D-D

Technical specifications

Model	D1	D2	D3	D4	H	H1	H2	L	Z-d1	Z-D2
D-D-200	65	82	100	200	67,5	39	21	180	6-M6	3-M8 x 35
D-D-300	100	120	150	300	67,5	39	21	240	6-M6	3-M8 x 30
D-D-400	170	220	250	400	95	45	25	300	6-M6	3-M10 x 40
D-D-500	240	280	320	500	110	60	25	350	6-M6	3-M12 x 55
D-D-600	365	400	425	600	170	105	40	425	6-M12	6-M12 x 110
D-D-750	551,5	542,5	570	750	170	105	40	500	6-M12	6-M12 x 110

All information is subject to printing-, typing errors and modifications.

